



AIR 4XL™

The Vertex Air 4XL™ pond aerator is a super-efficient, affordable and safe system. In a typical pond with 8 foot depths, an Air 4XL™ can aerate approximately 9-11 acres depending on shape, slope, oxygen demand and other factors. Two 1/3 hp Brookwood™ SafeStart™ compressors, housed in our rustproof aluminum outdoor cabinet, feed four bottom mounted XL AirStations™ utilizing Vertex's MicronBubble™ technology. The rising force of millions of bubbles circulates the entire water column, entraining bottom water up to the surface allowing vital oxygen to be absorbed and poisonous gasses expelled.

With no electricity in the water, Vertex's aeration systems are safe for any type of water recreation. Our systems have a full two-year warranty plus a five-year warranty against rust and corrosion on the cabinet, five-year warranty on the AirStations™ and a 15-year warranty on BottomLine™ supply tubing

FEATURES

AIRSTATIONXL™

- ◆ Independently tested pumping rate, up to 37,156 GPM
- ◆ Sixteen 9" flexible membrane discs with MicronBubble™ technology
- ◆ Self-cleaning, low maintenance and five year warranty
- ◆ Rugged EPDM construction
- ◆ Vacuum formed and sonic welded HDPE base unit
- ◆ Lipped edge prevents sinking into soft bottom sediments
- ◆ Five-year warranty

BROOKWOOD™ COMPRESSOR

- ◆ Two-year Vertex warranty
- ◆ Vertex SafeStart™ Technology
- ◆ U.L., 115 volt, 25 PSI
- ◆ Thermal overload protection
- ◆ (2) 1/3 hp for low electrical costs
- ◆ 2-3 year extended duty cycle before scheduled maintenance

QUIETAIR™ CABINET

- ◆ Class "A" GFCI protection on all 115V circuits
- ◆ Powder coated aluminum for a durable attractive finish
- ◆ Two high capacity 290 CFM fans
- ◆ Easy access design with barrel lock for security
- ◆ Easy plug-in connection to waterside electrical service
- ◆ Heavy duty mounting pad included
- ◆ Five-year warranty

BOTTOMLINE™ TUBING

- ◆ Over-sized 0.58" ID for high flow
- ◆ Heavy duty wall thickness for durability
- ◆ Self-weighted for easy installation
- ◆ Available in 100 and 500 feet increments
- ◆ 15-year Vertex warranty

BENEFITS TO THE LAKE

- ◆ High, independently tested pumping rate
- ◆ Entire water column circulated
- ◆ Increased oxygen levels throughout water column
- ◆ Elimination of low oxygen fish kills
- ◆ Reduced nutrient levels and associated algae growth
- ◆ Oxidized/reduced bottom muck
- ◆ Improved fisheries by expanding oxygenated habitat
- ◆ Reduced aquatic midge and mosquito insect hatches
- ◆ Elimination of foul odors from undesirable dissolved gasses
- ◆ Safe entry - no electricity in the water
- ◆ Extended warranties on all system components

SPECIFICATIONS: AIR 4XL™ LAKE AERATION SYSTEM

BROOKWOOD™ COMPRESSOR

(2)1/3hp, 115v, Single Phase piston type compressor. Built for continuous 24/7 operation and equipped with Vertex SafeStart™ technology allowing auto restart under maximum rated pressure without motor damage. Super-duty Brookwood™ compressors incorporate upgraded rotors, stators, valve plates, bearings and capacitors and are thermally protected, oil-free, and require no lubrication; just periodic cleaning of included washable air filter. Extended duty cycle is approximately 24 to 36 months for compressor maintenance, about 2 to 3 times the duty cycle of ordinary piston and rotary vane compressors. All Brookwood™ SafeStart™ compressors carry a two year warranty.

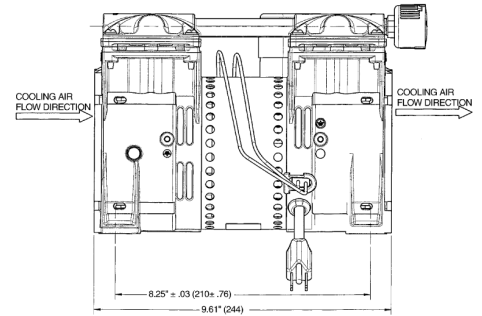

QUIETAIR™ CABINET

Enclosure comes equipped with barrel lock for security, fully gasketed and constructed of aluminum with gray electrostatically-bonded powder coating to provide lifetime warranty against rust. Enclosure furnished with stamped ventilation or grill to insure forced air circulation and an integral cooling fan with thermal protection, producing 290 CFM to guard against excessive compressor operating temperatures. Cabinet provided with HDPE mounting pad (24" x 24" x 2"). ENCLOSURE COMES WITH CLASS A GFCI PROTECTION ON BOTH THE COMPRESSOR AND FAN CIRCUITS.

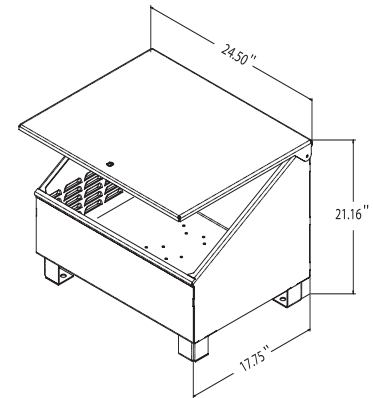

AIRSTATIONXL™ ASSEMBLY

Diffuser station shall consist of four self-cleaning, 9" diameter, flexible membrane diffusers of EPDM compound with 100% rebound memory, each producing millions of fine 500 to 3000 micron bubbles – the majority 500 to 1000 microns. Each diffuser station shall be equipped with vacuum-formed HDPE base, sonic spot-welded to provide unit integrity. Base unit (17.25"L x 13.25"W x 3.35"D) shall be of hollow chamber design for the addition of inert pea gravel ballast and have lipped design to prevent settling into soft bottom sediments.

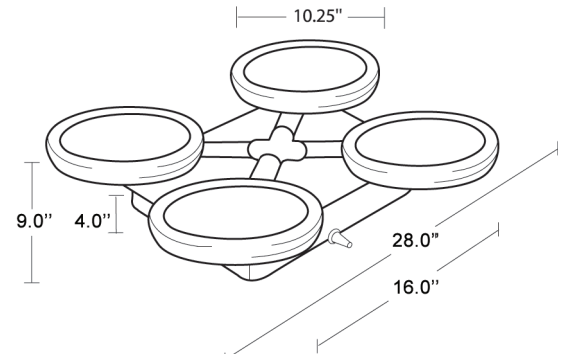

BOTTOMLINE™ SUPPLY TUBING

Self-weighted, direct burial submersible tubing for connection from compressor to diffuser stations. Tubing shall be of flexible PVC composite construction for use with standard PVC solvent weld cement and 0.5" insert fittings. Tubing shall have 0.58" I.D. and 0.235" wall thickness for long term durability and protection against punctures. Remains flexible in cold temperatures.

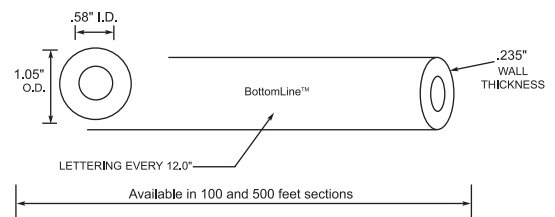

(800) 432-4302 / Fax (954) 977-7877
www.vertexwaterfeatures.com / e-mail: info@vertexwaterfeatures.com

Install all electrical equipment in accordance with Article 680 of the National Electrical Code and all local codes. Vertex Water Features reserves the right to improve and change our designs and/or specifications of our aerators without notice or obligation.
© 2007 Vertex Water Features